

Features

- Industrial Display
- Flat front panel touch screen
- Fanless design
- Wide range DC 9~36V power input
- IP66 compliant front panel
- VGA/DVI-D/HDMI/DP input
- System power LED light
- High Brightness LCD and Auto Dimming for option
- Support protective AR glass for option (non-touch version)

Specifications

I/O Port	
VGA	1 x VGA
DVI	1 x DVI-D (share with HDMI)
DP	1 x DP
HDMI	1 x HDMI (share with DVI-D)
Audio	1 x Audio line-in phone jack
OSD Control Membrane	OSD at rear side
Power	1 x 3-pin terminal block for DC 9~36V power input
Others	1 x USB type B for touch control Optional I/O: 1 x Speaker 1 x RS-232 DB-9 for touch control

Display	Standard	High Brightness Optional
Display Type	12.1" Wide TFT-LCD	12.1" Wide TFT-LCD
Max. Resolution	1280 x 800	1280 x 800
Max. Color	16.7M	16.7M
Luminance (cd/m ²)	600	1000
View Angle	170(H) / 170(V)	176(H) / 176(V)
Contrast	1000:1	1000:1
Backlight Lifetime	50,000 hrs	50,000 hrs

Touch Screen	
Type	Resistive Touch (for AR Model) Projected Capacitive Touch (for AP Model) Glass (for AG model)
Interface	USB default (Resistive / Projected Capacitive Touch) RS-232 Option (Resistive Touch)
Light Transmission(%)	Resistive Touch : over 80% Projected Capacitive Touch : over 90%

Power	
Power Input	DC 9~36V
Power Consumption	ARCDIS-112WAP: 13.2W

Mechanical	
Construction	Aluminum Die-casting Chassis
Mounting	Panel Mount / VESA Mount 100 x 100
IP Rating	IP66 Compliant Front Panel
Dimensions (WxHxD)	328 x 227 x 57.6 mm
Net Weight	2.7 kg

Dimensions

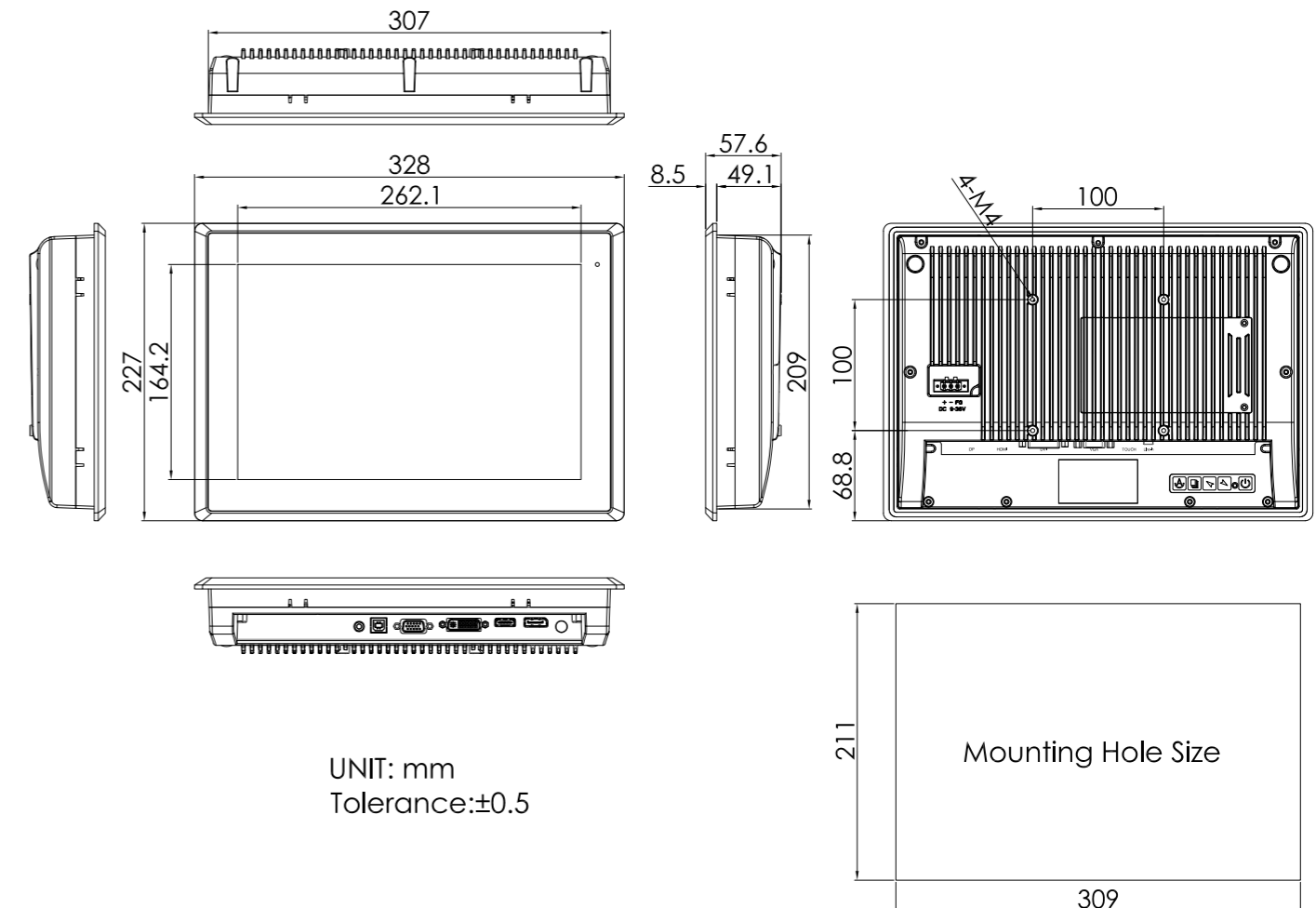

Environmental	
Operating Temperature	0~50°C / -20~60°C for option
Storage Temperature	-30~70°C
Humidity	10 to 95% @ 40°C, non-condensing
Certificate	CE/FCC, Class A

Ordering Information	
ARCDIS-112WAR	12.1" WXGA FPD Industrial display, Resistive touch window, VGA, DVI-D, HDMI, and DP input, 5 keys Rear OSD, DC 9~36V power input with adapter, Aluminum Die-casting Chassis
ARCDIS-112WAP	12.1" WXGA FPD Industrial display, Projected Capacitive touch screen, VGA, DVI-D, HDMI, and DP input, 5 keys Rear OSD, DC 9~36V power input with adapter, Aluminum Die-casting Chassis