

Features

- 12.1" Wide Industrial Compact Size Panel PC
- 8th Gen. Intel Core i3/i5, CPU built-in
- 1 x 260-pin SO-DIMM DDR4 slot, up to 32GB 2400MHz
- Flat Front Panel Touch Screen with IP66 Front Bezel
- Fanless Design
- DC 9~36V Wide-Ranging Power Input
- Support Expansion via Full-size Mini PCIe and M.2 slots
- Support TPM2.0 Hardware Security
- High Brightness 1,000 nits for option

Specifications

System	
CPU	Onboard 8th Gen Intel Core i3-8145UE Processor(2C/4T,2.2GHz)/ Intel Core i5-8365UE Processor(4C/8T,1.6GHz)
System Chipset	SoC
Memory	1 x 260-pin SO-DIMM up to 32GB DDR4 2400MHz

I/O Port	
USB	4 x USB 3.0 type A
Serial	1 x DB-9 Connector, Including: * 1 x RS-232(RTS, Rx, Tx, CTS), pin1 RTS/5V/12V selectable via jumper (COM1) * 1 x RS-232(Tx, Rx)/ 422/485(COM2) by Y Cable
Audio	1 x Audio Line Out
DP	1 x DP Port
LAN	2 x GbE LAN RJ-45
Power	1 x 3-pin Terminal Block Connector 1 x 2-pin Power Switch Connector
Option	VESA Stand 4G LTE WiFi 4/5/6+ BT 4 x USB 2.0 type A (TB-528U4) 4 x USB 2.0 type A + 1 x Mini-PCIe + 1 x SIM slot (TB-528U4ME1) 2 x COM (RS-232) (TB-528C2) 1 x COM (RS-232) + 2 x USB 2.0 (TB-528C1U2) 1 x COM (RS-232) + 2 x USB 2.0 + 1 x Power Button (TB-528C1U2P1) 2 x COM (RS-232) + 1 x Mini-PCIe slot + 1 x SIM slot (TB-528C2ME1) 2 x COM (RS-422/485, isolated) (TB-528C2I) 2 x CAN (TB-528CAN2) 1 x LAN + 2 x USB 2.0 type A (TB-528E1U2) Backup Battery 21W/10.8V/1.95Ah(3S1P) (TB-528 Series or backup battery only be in either one)

Storage Space	
Storage	1 x M.2 M Key slot (Support PCIe/SATA; 2242/2280, Default 2242)

Expansion	
Onboard expansion bus	1 x Mini-PCIe slot (full size) 1 x Nano SIM Card Holder

Display	Standard	High Brightness Optional
Display Type	12.1" Wide TFT-LCD	12.1" Wide TFT-LCD
Max. Resolution	1280 x 800	1280 x 800
Max. Color	16.7M	16.7M
Luminance (cd/m ²)	600	1000
View Angle	170(H)/170(V)	176(H)/176(V)
Contrast	1000:1	700:1
Backlight Lifetime	50,000 hrs	50,000 hrs

Dimensions

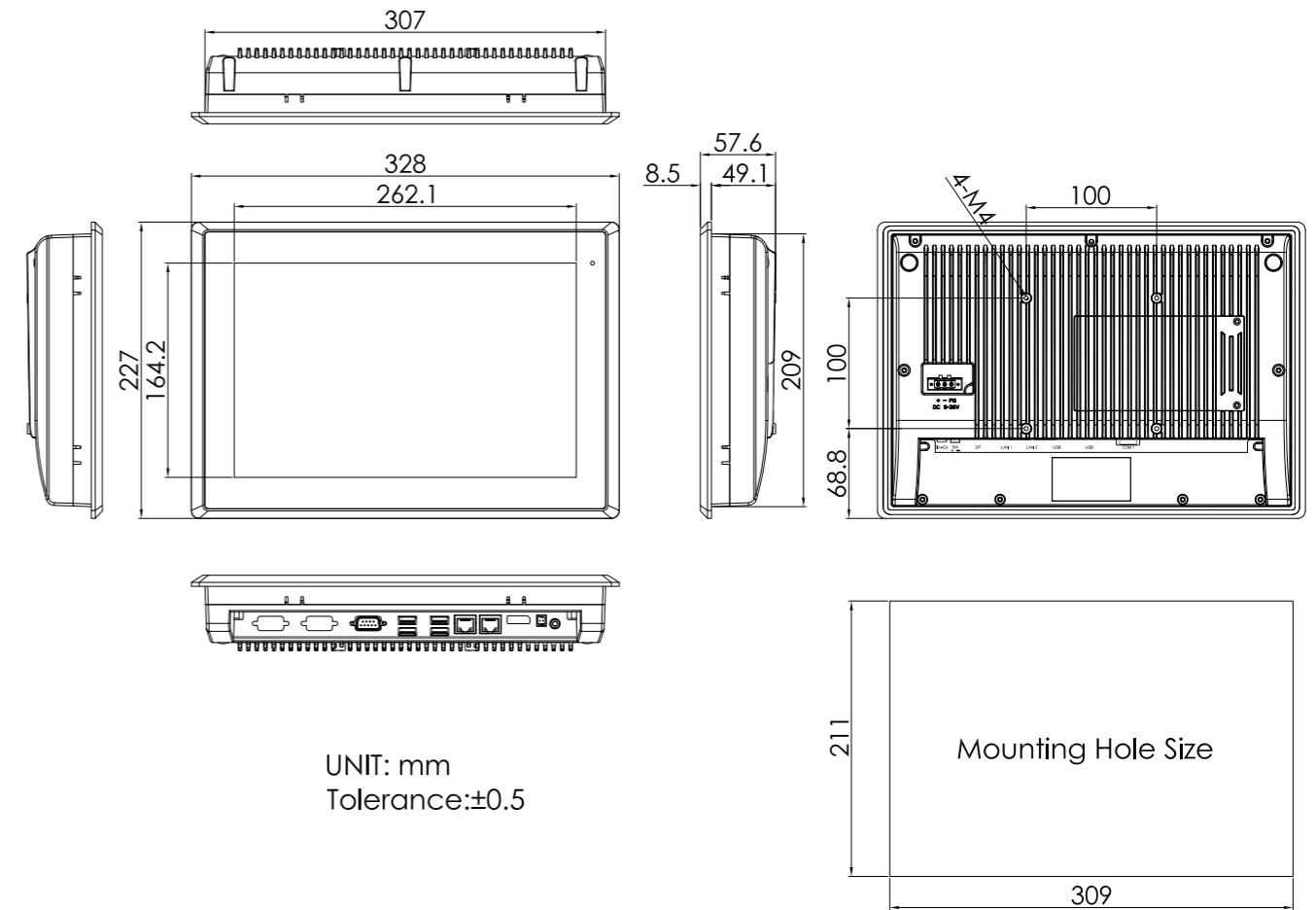

Touch Screen	
Type	Resistive Touch (for BR Model) Projected Capacitive Touch (for BP Model)
Interface	USB
Light Transmission(%)	Resistive Touch: 80% Projected Capacitive Touch: 90%

Power	
Power Input	DC 9~36V
Power Consumption	ARCHMI-912WBP: 50W (MAX)

Mechanical	
Construction	Aluminum Die-casting Chassis
Mounting	Panel Mount, VESA 100 x 100
Dimensions (WxHxD)	328 x 227 x 57.6 mm
IP Rating	IP66 Compliant Front Bezel
Net Weight	2.9 kg

Environmental	
Operating Temperature	0~50°C / -20~60°C (option)
Storage Temperature	-30~70°C
Humidity	10 to 95%@ 40°C, non-condensing
Certificate	CE / FCC, Class A

Operating System Support	
Win10 IoT	

*PoE limitation: CPU turbo off, rear I/O no loading, 70% LED backlight, PSE cable length < 50m