

Features

- 10.1" Food Industrial Panel PC
- Intel Celeron N2930 Processor
- Onboard 4GB DDR3L 1333MHz
- Flat and Stainless Steel Front Panel Design
- Fanless Design
- Wide Range DC 9~36V Power Input

Specifications

System	
CPU	Onboard Intel Celeron N2930 Processor (2M Cache, 1.83GHz)
System Chipset	SoC
Memory	Onboard 4GB DDR3L SDRAM
IO Port	
USB	2 x USB 3.0 type A
Serial / Parallel	1 x RS-232/422/485 DB-9, default RS-232 (COM1) 1 x RS-232 DB-9 (COM2)
LAN	2 x GbE LAN RJ-45
Audio	1 x Line Out
Power	1 x 3-pin Terminal Block Connector 1 x 2-pin Power Switch Connector
Option	VESA Stand 4G LTE/WiFi/ BT 4 x USB 2.0 type A (TB-528U4) 4 x USB 2.0 type A + 1 x Mini-PCle + 1 x SIM slot (TB-528U4ME1) 2 x COM (RS-232) (TB-528C2) 1 x COM (RS-232) + 2 x USB 2.0 (TB-528C1U2) 1 x COM (RS-232) + 2 x USB 2.0 + 1 x Power Button (TB-528C1U2P1) 2 x COM (RS-232) + 1 x Mini-PCle slot + 1 x SIM slot (TB-528C2ME1) 2 x COM (RS-422/485, isolated) (TB-528C2I) 2 x CAN (TB-528CAN2) 1 x LAN + 2 x USB 2.0 type A (TB-528E1U2) 1 x LAN(25W non-isolated PoE PD) + 2 x USB 2.0 type A (TB-528NE1U2POE)* 1 x LAN(25W isolated PoE PD) + 2 x USB 2.0 type A (TB-528E1U2POE)* Backup Battery 21W/10.8V/1.95Ah(3S1P) System is only allowed to build in either I/O board TB-528 series or backup battery Either high brightness panel or backup battery can be installed in HMI

Storage Space	
HDD	1 x 2.5" SATA HDD space (Easily Accessible)
Movable Device	1 x Internal Micro SD slot onboard

Expansion	
On board expansion bus	1 x Mini-PCle (full size) 1 x Micro SIM slot

Display	Standard	High Brightness Optional
Display Type	10.1" TFT-LCD	10.1" TFT-LCD
Max. Resolution	1280 x 800	1280 x 800
Max. Color	16.7M	16.7M
Luminance (cd/m ²)	350	1000
View Angle	170(H)/170(V)	170(H)/170(V)
Contrast	800:1	1300:1
Backlight Lifetime	30,000 hrs	50,000 hrs

Touch Screen	
Type	Projected Capacitive Touch (for AP model) Resistive Touch (for AR model)
Interface	USB
Light Transmission(%)	Resistive Touch: 80% Projected Capacitive: 90%

Dimensions

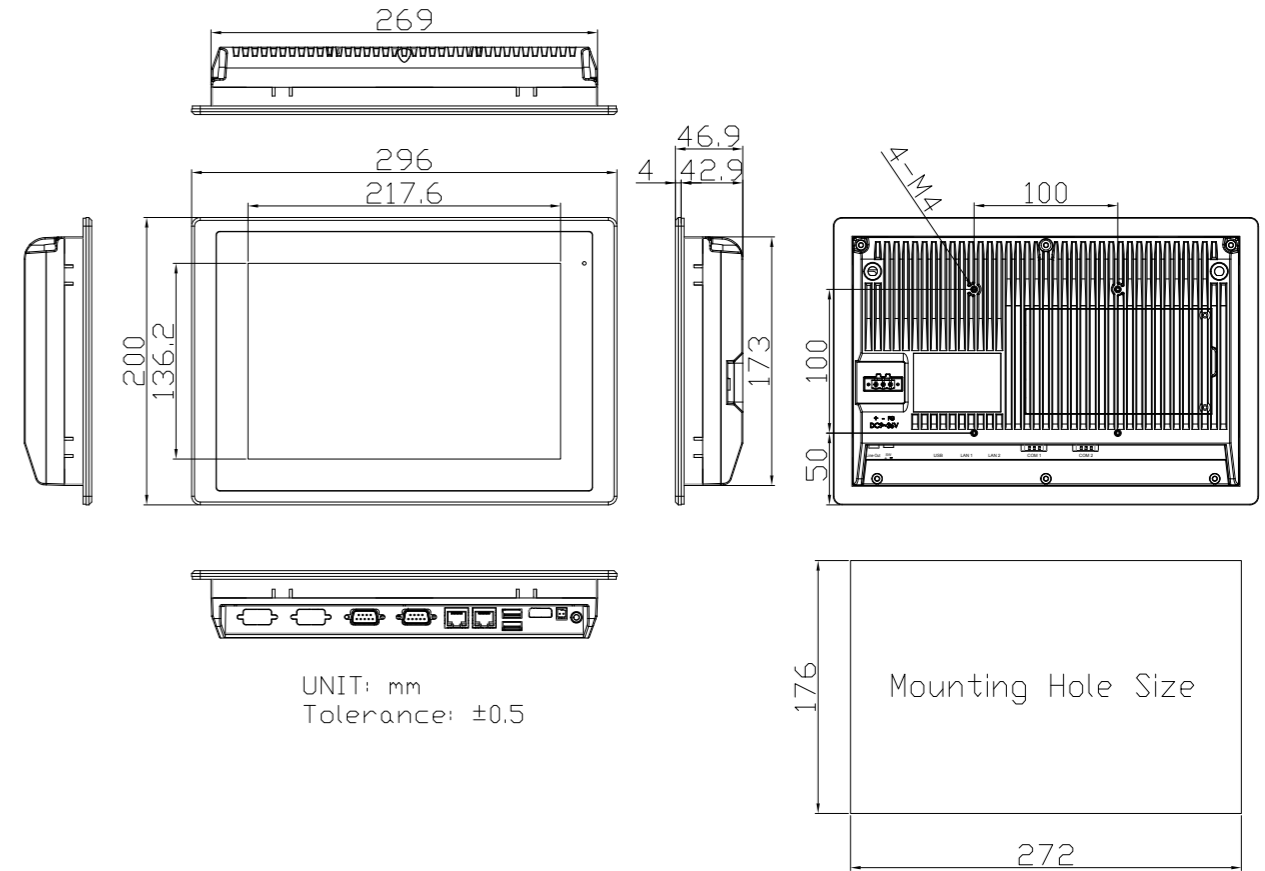

Power	
Power Input	DC 9~36V
Power Consumption	FABS-810P: 30W (MAX)

Mechanical	
Construction	304 Stainless Steel Front Bezel (default) 316 Stainless Steel Front Bezel (for option) Aluminum Die-casting Back Cover
Mounting	Panel Mount, VESA Mount 100 x 100
IP Rating	IP66/IP69K Compliant Front Bezel
Dimensions	296 x 200 x 46.9 mm
Net Weight	2.5 kg

Environmental	
Operating Temperature	0~50°C/ -20~60°C (option)
Storage Temperature	-30~70°C
Humidity	10 to 90%@ 40°C, non-condensing
Certificate	CE/FCC Class A EN 1672-2 for P Model

Operating System Support	
Windows 10 IoT	

Ordering Information	
FABS-810P/R (Barebone)	10.1" WXGA fanless HMI barebone with Celeron N2930(1.83.GHz) CPU, 4GB DDR3L RAM, Projected Capacitive/Resistive Touch, 9~36V DC input with adapter, Stainless front bezel and Aluminum chassis

*PoE limitation: CPU turbo off, rear I/O no loading, 70% LED backlight, PSE cable length < 50m