

Features

- 15" TFT-LCD
- Intel 6th Gen. Core i3/i5 Processor
- SUS 316 Stainless Steel
- Total IP66 Grade with M12 Waterproof Connector
- Variety of IO applications
- Wide range DC 9~36V Power Input
- Support Panel Mount & VESA Mount
- Support Projected Capacitive Touch
- Full Flat Bezel and Fanless Design
- ATEX/IECEX Zone2, Zone22 and C1D2/C2D2/C3 Certified

Specifications

System	
CPU	Onboard 6th Gen Intel Core i3/i5 processor
System Chipset	SoC
Memory	1 x 260-pin SO-DIMM up to 16GB DDR4 2133MHz

IO Port	
USB	1 x M12 8-pin for 2 x USB 2.0 with waterproof cover and chain
Serial / Parallel	1 x M12 8-pin for COM1, RS-232/422/485, default RS-232, with waterproof cover and chain
LAN	2 x M12 8-pin for LAN with waterproof cover and chain
Graph	1 x M12 8-pin for VGA with waterproof cover and chain
Power	1 x M12 3-pin for DC power connector with waterproof cover and chain

Storage Space	
HDD	1 x 2.5" HDD or SSD space 1 x mSATA space

Expansion	
Expansion slot	1 x Mini-PCIe (full size)

Display	Standard	High Brightness Optional
Display Type	15" TFT-LCD	15" TFT-LCD
Max. Resolution	1024 x 768	1024 x 768
Max. Color	16.2M	262K
Luminance (cd/m ²)	450	1000
View Angle	160(H)/150(V)	160(H)/150(V)
Contrast	800:1	800:1
Backlight Lifetime	70,000 hrs	50,000 hrs

Touch Screen	
Type	Projected Capacitive Touch
Interface	USB
Light Transmission(%)	90%

Power	
Power Input	DC 9~36V
Power Consumption	AEx-915AP: 21W

Mechanical	
Construction	316 stainless steel chassis
Mounting	VESA mount 100 x 100, Panel mount (option)
IP Rating	Total IP66
Dimensions	399 x 324 x 70 mm
Net Weight	9.6 kg

Dimensions

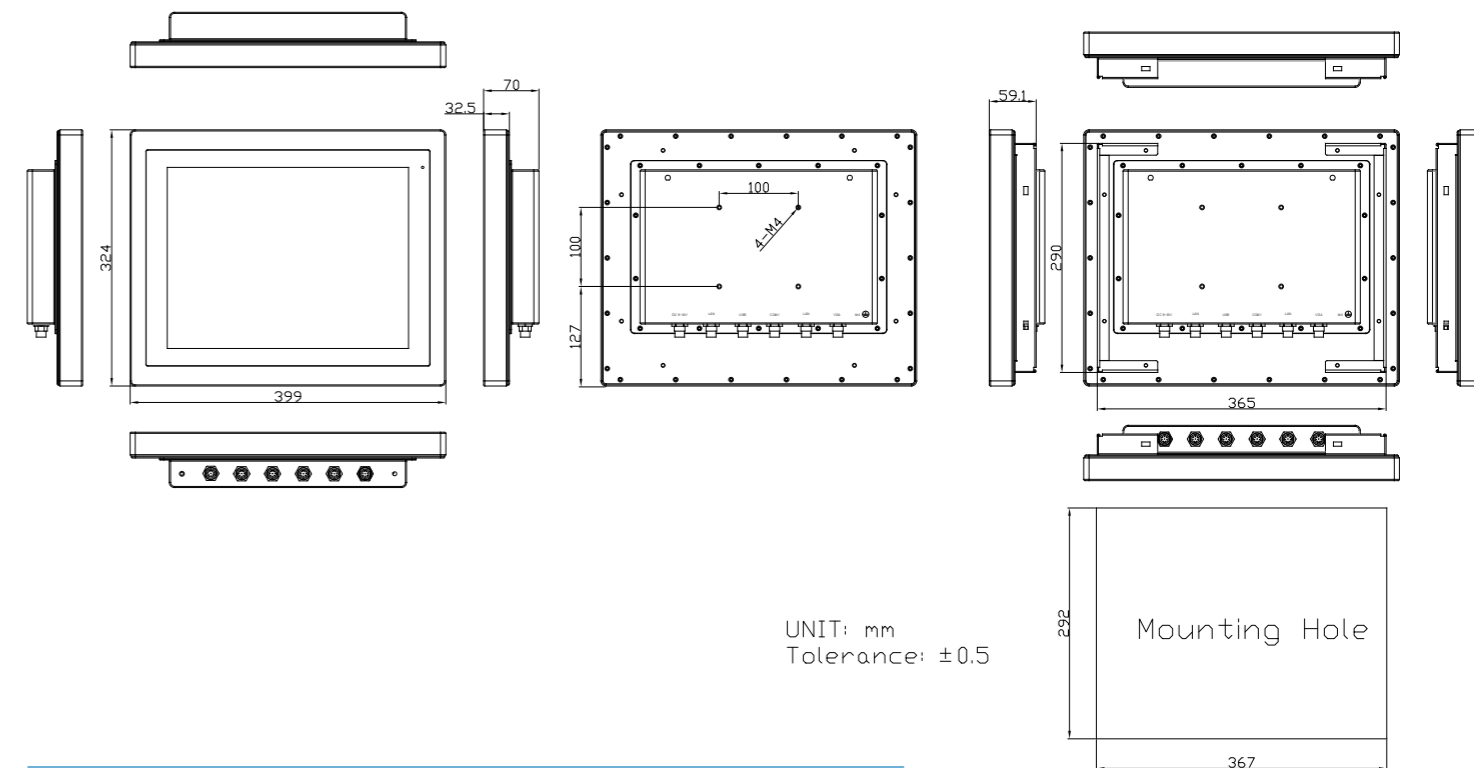

Environmental	
Operating Temperature	-20~60°C
Storage Temperature	-30~70°C
Humidity	10 to 95% @ 40°C, non- condensing
Safety	CSA C22.2 No.61010
Certificate	CE / FCC Class A ATEX / IECEX Zone2 Ex ec ic IIC T4 Gc ATEX / IECEX Zone22 Ex tc IIIC T135°C Dc Class I, Division2, Group A,B,C,D,T4 Class II, Division2, Group F,G, T135°C Class III ANSI/ISA 12.12-01-2013 CSA Std., C22 No213-1987

Operating System Support	
Windows embedded 7	
Windows embedded 8.1	
Windows 10 IoT ENT LTSC	

Ordering Information	
AEX-915AP	15" XGA IP66 Intel Core I5-6300U 2.4GHz, fan less panel PC, 1 x SO-DIMM(260pins), Up to 16G DDR4 2133MHz, 1 x 256GB 2.5" MLC SSD, 1 x 64GB mSATA MLC SSD, Projected capacitive touch, DC9~36V power input with power adapter, 316 stainless steel enclosure, support VESA Mount, WT-20~60 Accessory : 1 x M12 for 2 x USB2.0 Cable, 2 x M12 LAN cable, 1 x M12 COM Cable, 1 x VGA Cable, 1 x 3pin power input cable (w/o Adapter)
AEX-915APH	15" XGA HB1000nits IP66 Intel Core I5-6300U 2.4GHz, fan less panel PC, 1 x SO-DIMM(260pins), Up to 16G DDR4 2133MHz, 1 x 256GB 2.5" MLC SSD, 1 x 64GB mSATA MLC SSD, Projected capacitive touch, DC9~36V power input with power adapter, 316 stainless steel enclosure, support VESA Mount, WT-20~60 Accessory : 1 x M12 for 2 x USB2.0 Cable, 2 x M12 LAN cable, 1 x M12 COM Cable, 1 x VGA Cable, 1 x 3pin power input cable (w/o Adapter)