



Features

- Bi-directional Energy
- True RMS Power Measurements
- Energy Analysis for 3P4W, 3P3W, 1P3W, 1P2W
- Direct input of secondary side 1A/5A CT
- Voltage Measurements Up to 500 V
- W Accuracy Better than 0.5% (PF=1)
- Total Harmonic Distortion (THD)
- Supports RS-485, Ethernet (PoE) or CANopen Interface
- Supports Modbus RTU/Modbus TCP or CANopen Protocol
- IEC 61010-1 and EN 61010-1



ICP DAS brings the most powerful, cost-effective, advanced Smart Power Meters PM-3033 series that gives you access to real-time electric usage for three-phase power measurement. With its high accuracy ($<0.5\%$, $PF=1$), the PM-3033 series can be applied to both low voltage primary side and/or medium/high voltage secondary side and enables the users to obtain reliable and accurate energy consumption readings from the monitored equipments in real time under operation. Direct input from "secondary side 1A/5A" type CTs. Dedicated CTs are no longer needed, which lowers the cost of implementation. It operates over a wide input voltages range $10 \sim 500 \text{ V}_{AC}$ which allows worldwide compatibility. It also supports Modbus RTU, Modbus TCP or CANopen protocols for easy integration.

Specifications

Models	PM-3033	PM-3033-MTCP	PM-3033-CPS
AC Power Measurement			
Wiring	3P4W-3CT, 3P3W-2CT, 3P3W-3CT, 1P2W-1CT, 1P3W-2CT		
Measurement Voltage	10 ~ 500 V		
Measurement Current	1A or 5A		
Measurement Frequency	50/60 Hz		
W Accuracy	Better than 0.5% (PF=1)		
Power Parameter Measurement	True RMS voltage (V_{rms}), True RMS current (I_{rms}), Active Power (kW), Active Energy (kWh), Apparent Power (kVA), Apparent Energy (kVAh), Reactive Power (kVAR), Reactive Energy (kVARh), Power Factor (PF), Frequency		
Data Update Rate	1 Second		
Communication			
RS-485	Protocol	Modbus RTU	-
	Baud Rate	9600, 19200 (default), 38400, 115200; DIP Switch Selectable	-
	Data Format	N,8,1 (default); N,8,2; E,8,1; E,8,2; O,8,1; O,8,2	-
	Isolation	3000 V _{DC}	-
Ethernet (PoE)	Protocol	-	Modbus TCP
CANopen	Protocol	-	CANopen
	Baud Rate	-	125 k (default), 250 k, 500 k, 1 M; DIP Switch Selectable
	Isolation	-	3000 V _{DC}
Power			
Power Input	+12 ~ 48 V _{DC}	+12 ~ 48 V _{DC} or PoE	+12 ~ 48 V _{DC}
Power Consumption	2 W		
Environment			
Temperature	Operating Temperature: -20 ~ +70 °C / Storage Temperature: -25 ~ +80 °C		
Ambient Relative Humidity	10% ~ 90% RH, Non-condensing		

CT Installation and Wiring

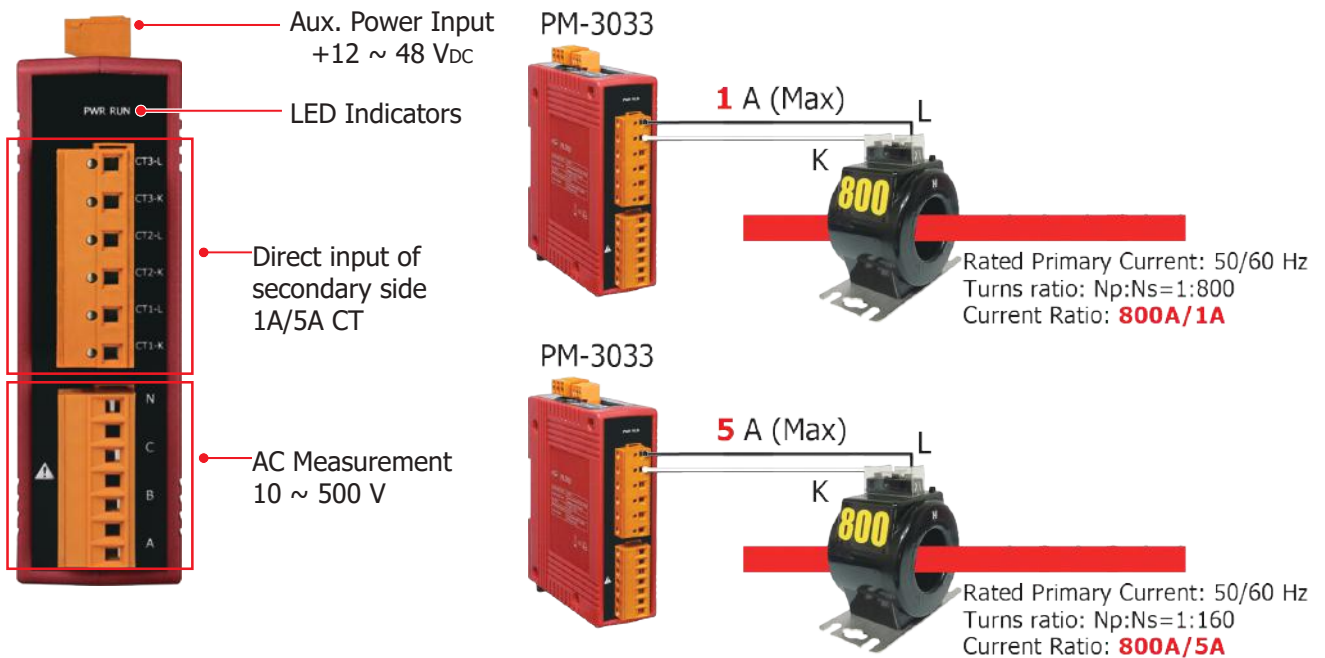

Dimensions (Units: mm)

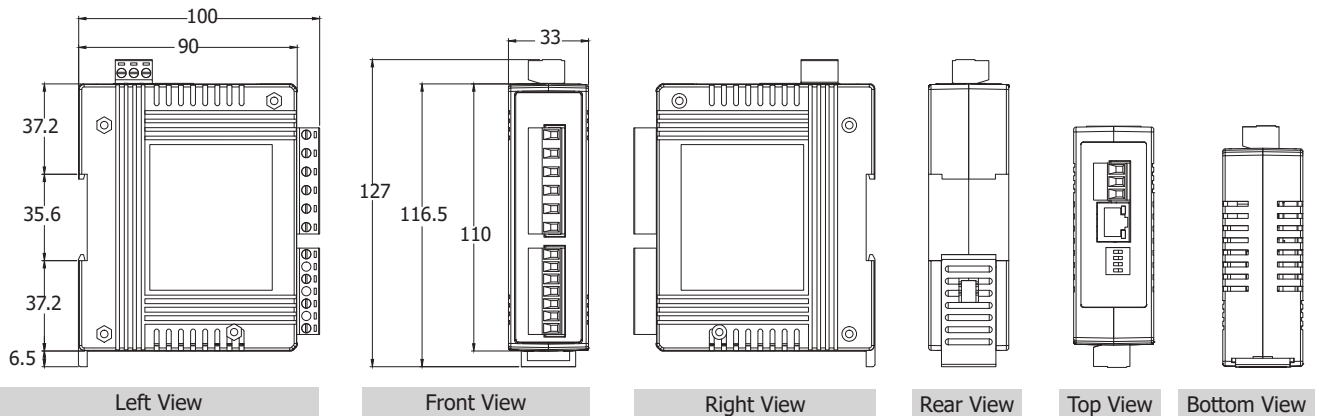

Selection Guide

PM-3033 - X X X

□: RS-485
□: CANopen
□: Modbus TCP

Ordering Information

RS-485 Interface	
PM-3033 CR	Modbus RTU, 3-phase power meter (1A/5A CT Input type) (RoHS)
Ethernet Interface	
PM-3033-MTCP CR	Modbus TCP, 3-phase power meter (1A/5A CT Input type) (RoHS)
CAN bus Interface	
PM-3033-CPS CR	CANopen, 3-phase power meter (1A/5A CT Input type) (RoHS)