



iSN-104 / iSN-104-E

4-channel Liquid Leak Detection Module

Features

- 4-ch Liquid Leak Detection
- Water Leakage and cable break detection triggers and audible alarm
- A mute button to silence the audible alarm
- Five LED indicators to display the status of the power and the alarm
- Liquid Leak Detection Cable and Extended Cable can be up to 500 meters
- Sensitivity adjustable detection
- Supports the DCON and the Modbus RTU Protocols
- Embedded Dual Watchdog and iSN-104-E supports Modbus TCP/UDP
- Tiny Form Factor with Easy Screw Mounting
- Includes Redundant Power Inputs: PoE and DC Input (iSN-104-E)



Introduction

The iSN-104 Liquid Leak Detection Module is a low-cost intelligent liquid leak detection device that can be used to directly control triggers and audible alarm. No additional conversion module is needed and the iSN-104 can be easily integrated with a variety of monitoring systems to achieve remote alarm and remote device control. The iSN-104 Liquid Leak Detection module can be used to monitor double-core leader cable lengths of up to 500 meters, and can be used with both the extended cable and its included liquid leak detection cable. The module can be easily integrated with other collection hosts connected to the network. The iSN-104 is suitable for real-time leak detection in critical locations, such as computer room base stations, warehouses, libraries, museums and industrial sites, and also for air handling equipment, refrigeration units, liquid containers, or pump tanks, etc., where there is a need to monitor any leakage of the equipment.

When required, communication with the iSN-104 can be programmed based on the Modbus RTU protocol, with the added benefit that different addresses can be configured via hardware to allow for Modbus RTU communication. iSN-104-E with Ethernet and PoE, meaning that the device can be easily integrated into existing HMI or SCADA systems, ensuring trouble-free maintenance in distributed control systems.

Specifications

EMS Protection	
EFT (IEC 61000-4-4)	±4 kV for Power
ESD (IEC 61000-4-2)	±8 kV Air for Random Point
LED Indicators	
Status	1 as Power Indicator 4 as Alarm Indicator
System	
Alarm	For both liquid leak detection and cable-break detection.
Buzzer	Yes. Can be muted by a push button.
Liquid Leak Detection	
Channels	4
Liquid Type	Water, 2uS/cm
Sensor Type	Probe for point detection or Cable for line detection
Max. Cable Length	500 meters Includes liquid leak detection cable and extended cable.
Sensitivity Range	26 KΩ ~ 580 KΩ (rotary switch adjustable)
Cable-break Detection	Yes. For Liquids Leak Detection Cable CA-LLD-DC100X-Lxxx only.

COM Ports	iSN-104	iSN-104-E
Ports	1 x RS-485	10/100 Base-TX, 8-Pin RJ-45 x1
Baud Rate	Software Configuration: 1200 ~ 115200 bps	-
Data Format	(N,8,1), (O,8,1), (E,8,1), (N,8,2)	-
Protocol	Modbus RTU or DCON	Modbus TCP and MQTT
Power		
Reverse Polarity Protection	Yes	
Input Range	10 ~ 30 VDC	10 ~ 48 VDC
Powered from PoE	-	Yes, IEEE 802.3af, Class 1
Consumption	1.6 W Max.	
Mechanical		
Dimensions (mm)	72 x 95 x 57 (W x L x H)	
Installation	DIN-Rail Mounting	
Environmental		
Operating Temperature	-25 ~ +75 °C	
Storage Temperature	-30 ~ +80°C	
Humidity	10 ~ 90% RH, Non-condensing	

Applications

The iSN-104 is a leakage detection module used in water pipe leak monitoring in buildings with two working modes.

1. Work with the Liquids Leak Detection Cable that installed near the possible leaking pipe or area to detect leakage and cable break with alarm.
2. Work with the leakage probe that installed in fixed possible leak locations to detect.

The leakage monitoring is applied to the water pipes, fire pipes and sewage pipes of buildings, as well as the detecting of domestic water, drainage and electric equipment, which can effectively achieve water saving and ensure the safety of living. The iSN-104 can detect leakages, send out signal and alarms, combine with the WISE IoT Edge Controller or TPD/VPD Touch HMI, and to further integrate with the mobile APP or community system.

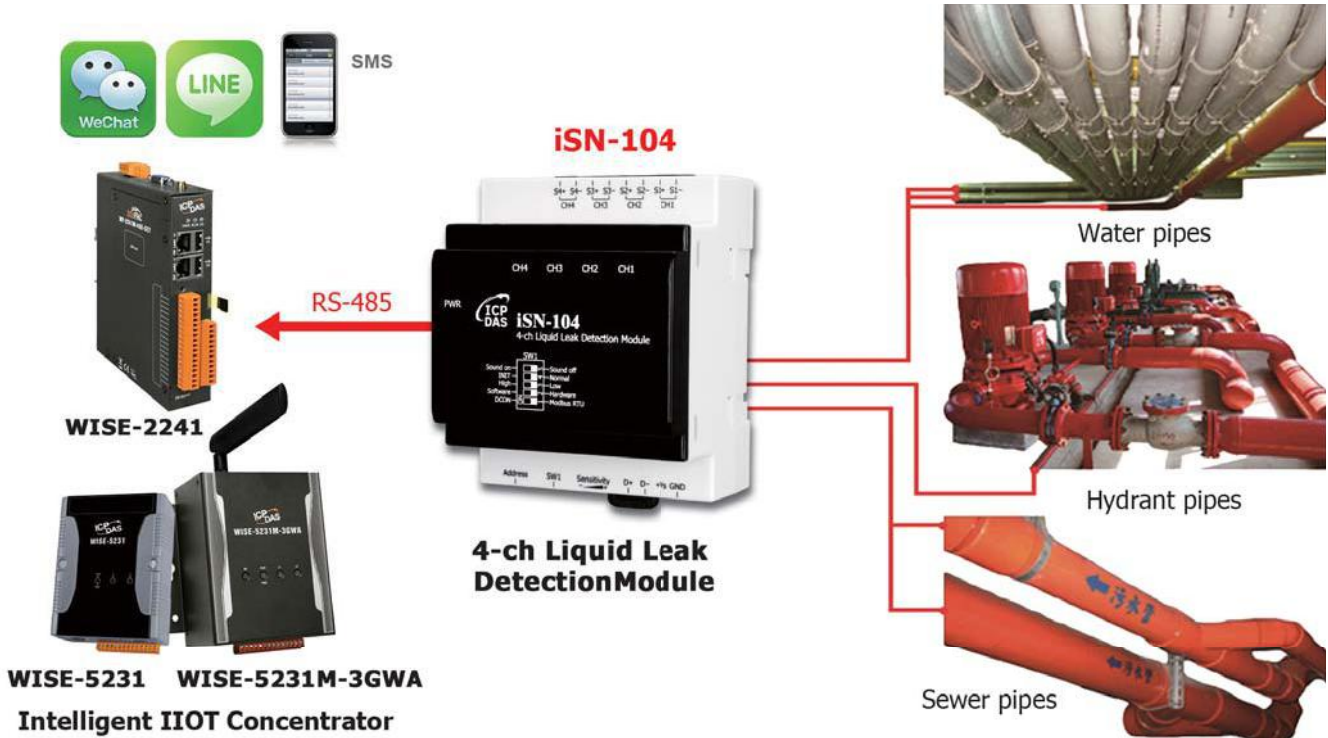

Wire Connections

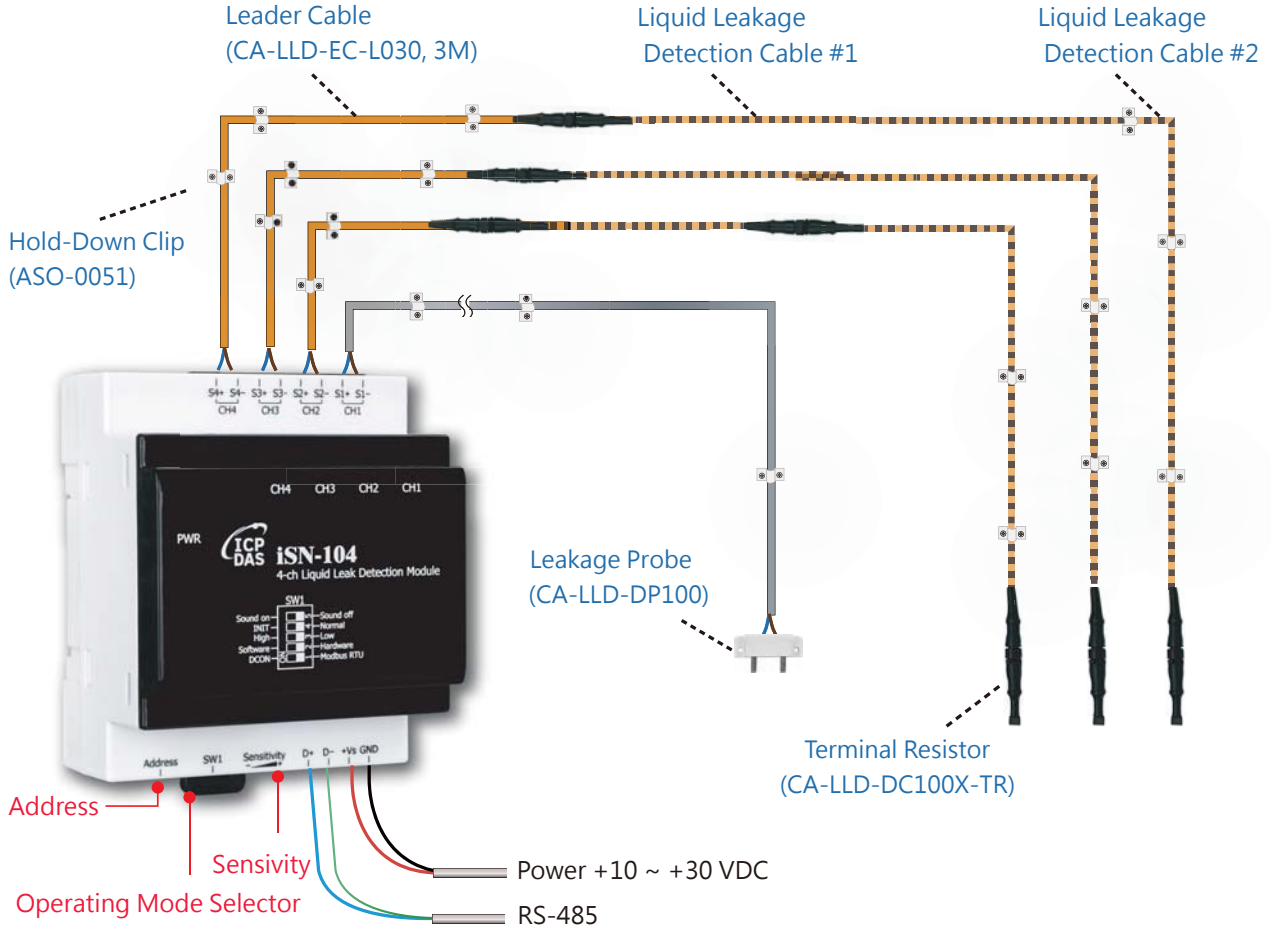

Configuration

iSN-104			
DIP Switch Description			
	SW1	ON	DCON Protocol
		OFF	Modbus RTU Protocol
	SW2	ON	Software Configuration
		OFF	Hardware Configuration
	SW3	ON	High Node Address
		OFF	Low Node Address
	SW4	ON	INIT Mode
		OFF	Normal Mode
	SW5	ON	Sound On
		OFF	Sound Off

iSN-104-E			
DIP Switch Description			
	SW1	ON	FW Update
		OFF	-
	SW2	ON	Sensitivity(SW)
		OFF	Sensitivity(HW)
	SW3	ON	-
		OFF	-
	SW4	ON	INIT
		OFF	Normal
	SW5	ON	Sound On
		OFF	Sound Off



PIN Assignments

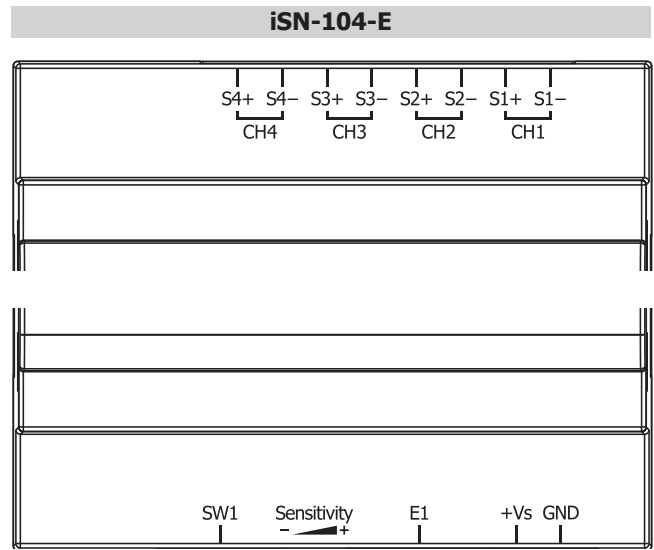
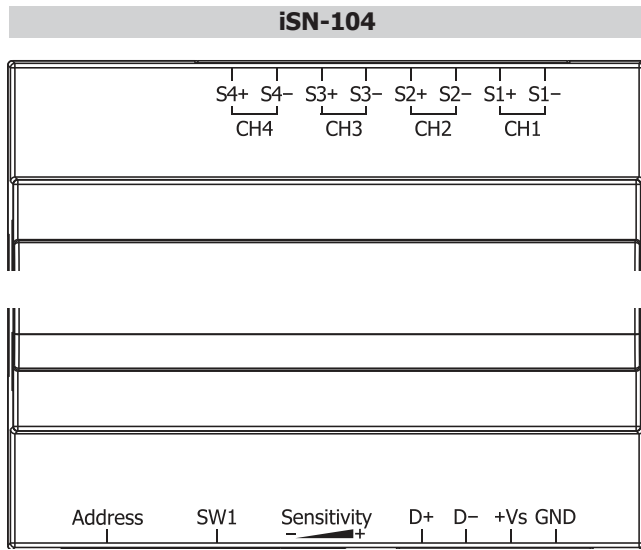

Dimensions (Units: mm)/PIN Assignments

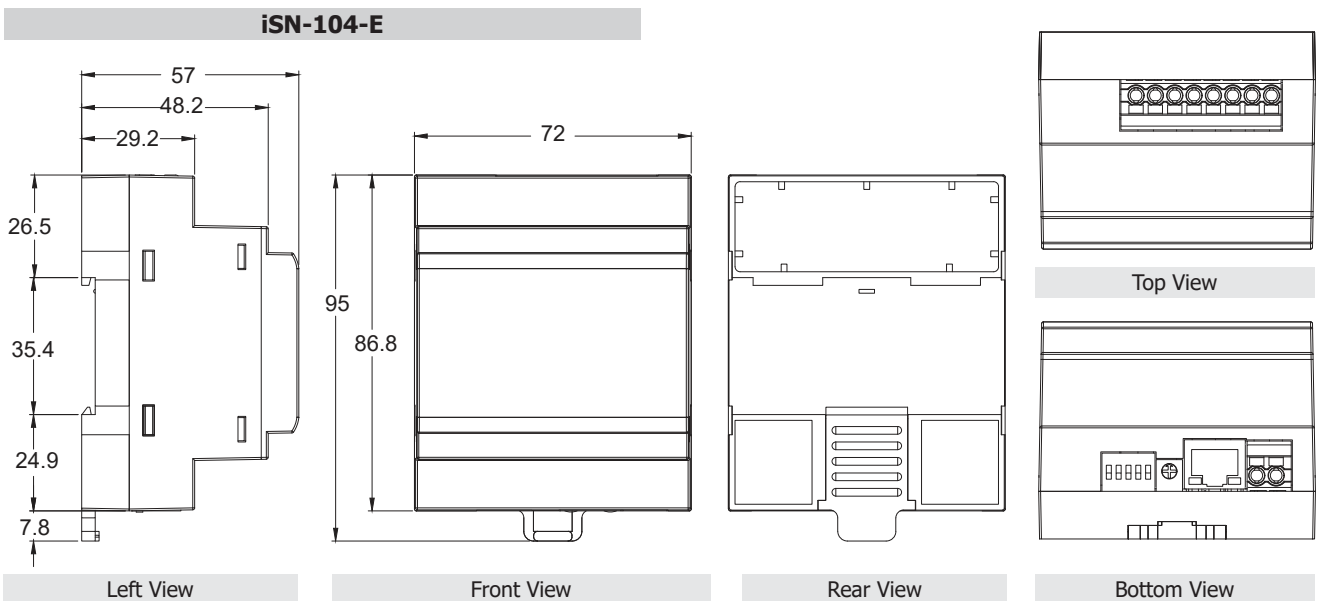
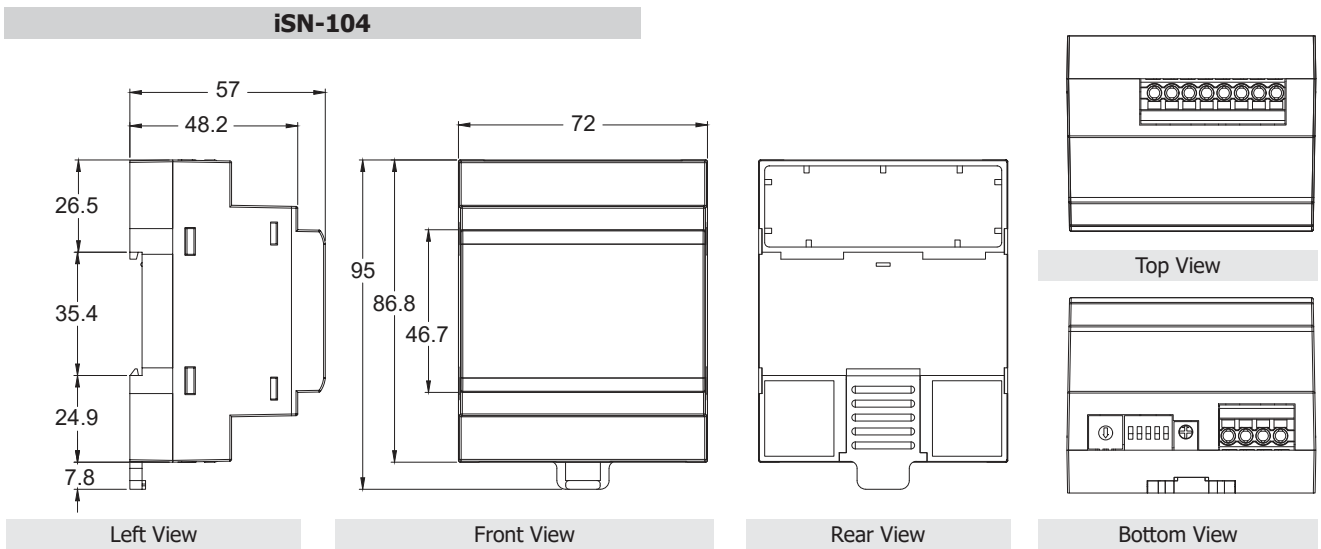

Ordering Information

iSN-104 CR	4-channel Liquid Leak Detection Module, Supports Modbus/RTU and DCON protocols (RoHS)
iSN-104-E CR	Ethernet I/O Module with 4-ch Liquid Leak Detection (RoHS)

Accessories

	tM-7520U CR	RS-232 to RS-485 converter (RoHS)		CA-LLD-DC100-L100 CA-LLD-DC100-L300 CA-LLD-DC100-L500	Liquids Leak Detection, Water Detection Cable w/o Position, 10 m /30 m /50 m length
	tM-7561 CR	USB to RS-485 converter (RoHS)		CA-LLD-DC100X-L010 CA-LLD-DC100X-L030 CA-LLD-DC100X-L050	Liquids Leak Detection, Water Proof Plug Male to Female Cable, 1 M/ 3 M/ 5 M (RoHS)
	I-7514U CR	4-channel RS-485 Hub (RoHS)		CA-LLD-EC-L030	Leader Cable, 3 M (RoHS)
	ASO-0052	90 Hold-Down Clip (include 50 pcs) (RoHS)		CA-LLD-DC100X-TR	Terminal Resistor, 2 MΩ (RoHS)
	ASO-0051	180 Hold-Down Clip (include 50 pcs) (RoHS)		CA-LLD-DP100	Leakage Probe (RoHS)

Liquids Leak Detection = LLD

