



I-8135W-G

5-port 10/100 Mbps Fast Ethernet Switch Module

Features

- 5-port RJ-45 Ethernet Switch
- Each port supports both 10/100 Mbps speed auto negotiation
- Full duplex IEEE 802.3x and half duplex backpressure flow control
- Automatic MDI/MDI-X crossover for plug-and-play
- 3.2 Gbps high performance memory bandwidth
- 512 Kbit frame buffer memory



Introduction

The I-8135W is a flexible and high performance five-port Ethernet switch module. It can be installed in PAC (XPAC, WinPAC, LinPAC, iPAC, ViewPAC, ...) and directly gets power from the backplane. An extra power adapter for an Ethernet switch is not need any more.

In your PAC solutions, if you want to expand Ethernet connection, I-8135W is good to replace regular Ethernet switches to save installation space and power adapter.

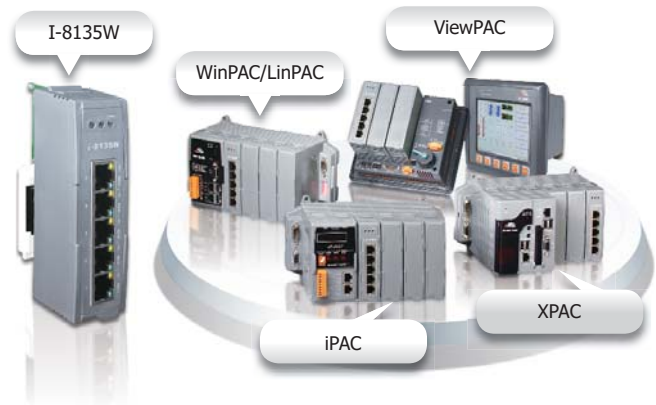

System Specifications

Technology	
Standards	IEEE 802.3, 802.3u, 802.3x
Processing Type	Store & forward, wire speed switching
MAC Addresses	1024
Memory Bandwidth	3.2 Gbps
Frame Buffer Memory	512 Kbit
Flow Control	IEEE802.3x flow control, back pressure flow control
Ethernet Switch	No external software required (for iP-8000, WP-8000, XP-8000, VP-23/25W)
Interface	
LED Indicators	1 LED as power indicator; 10 LEDs as speed and Link/Act indicators
Redundant Power	
Power Consumption	3 W
Mechanical	
Dimensions (W x L x H)	30 mm x 82 mm x 114 mm
Environment	
Operating Temperature	-25 °C ~ +75 °C
Storage Temperature	-40 °C ~ +85 °C
Ambient Relative Humidity	10% ~ 90% RH, Non-condensing

Internal I/O Structure

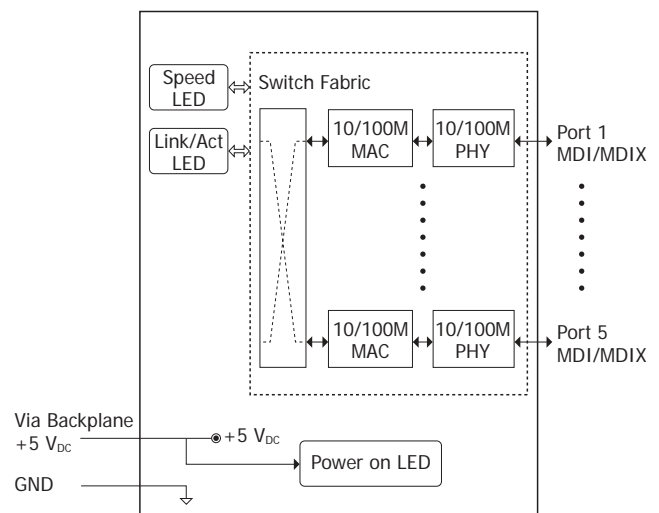

Applications

NS-205 with PAC (For standard Ethernet Switch application)



I-8135W with PAC

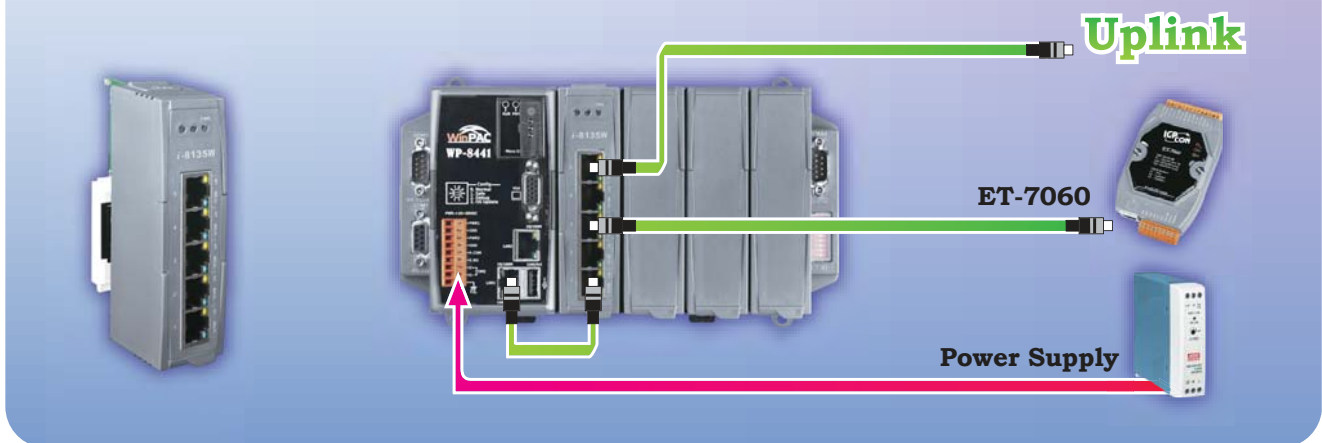

Dimensions (Units: mm)

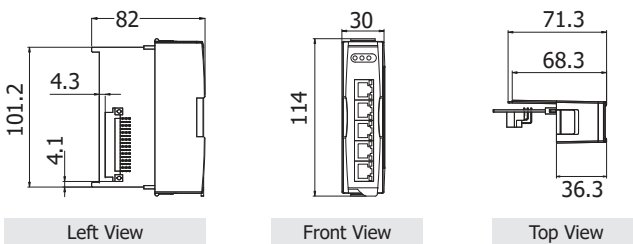

Pin Assignments

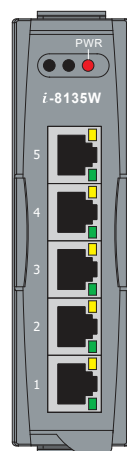

LED	Color	Description
PWR	Red	Power is ON
	Off	Power is Off
10/100M (Port 1)	Green	Link/Act
	Yellow	10/100 M
10/100M (Port 2)	Green	Link/Act
	Yellow	10/100 M
10/100M (Port 3)	Green	Link/Act
	Yellow	10/100 M
10/100M (Port 4)	Green	Link/Act
	Yellow	10/100 M
10/100M (Port 5)	Green	Link/Act
	Yellow	10/100 M

Ordering Information

I-8135W-G CR	5-port 10/100 Mbps Fast Ethernet Switch Module (Gray Cover) (RoHS)
--------------	--