



## I-8014W

250 kS/s, 16-bit, 16/8-channel  
Voltage/Current Input Module

## I-8014CW

250 kS/s, 16-bit, 8-channel  
Current Input Module

### Features

- Input Type  
I-8014W: 16 single-ended/8 differential input channels  
I-8014CW: 8 differential input channels
- Input Range  
I-8014W:  $\pm 1.25$  V,  $\pm 2.5$  V,  $\pm 5$  V,  $\pm 10$  V,  $\pm 20$  mA  
I-8014CW:  $\pm 20$  mA
- 16-bit, 250 kHz ADC converter
- 4 K-samples FIFO buffer
- External trigger mode: post-trigger
- Internal/external trigger start
- Magic Scan



### Introduction

The I-8014W/I-8014CW is a high performance Analog Input module. The I-8014W provides up to 16 single-ended or 8 differential input channels, while the I-8014CW provides up to 8 differential input channels. Both modules feature 16-bit resolution, 250 kS/s sampling rate, and a 4 k sample FIFO buffer, as well as providing 2500 VDC isolation protection.

The I-8014W/I-8014CW module contains an impressive scan function called Magic Scan, which is able to improve many of the functions and meet the demands of high-end users. Magic Scan function can scan the individual input channels at different input range and when performing single channel scan, the sampling rate can be maintained at 250 kS/s.

The Magic Scan function on the I-8014W/I-8014CW module can be operated in two ways. The first is a standard scan and the other is a Virtual Sample and Hold function. The cost of almost all AI Cards is high if it includes a Sample and Hold function, but ICP DAS can now offer a low-cost alternative.

#### Standard Mode

Each sampling clock only samples a single

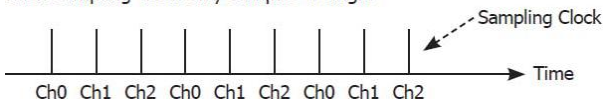

#### Virtual Sample and Hold Mode

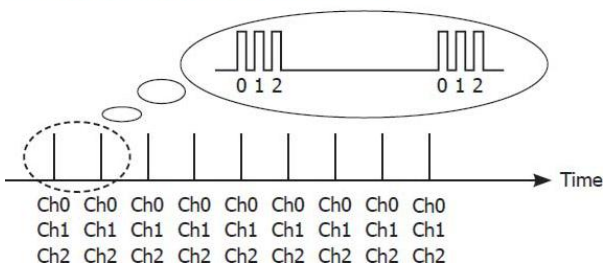

The I-8014W/I-8014CW module includes a 4 k sample onboard FIFO buffer for A/D conversion. The new FIFO technology uses a trigger interrupt signal, meaning that if the sampled count is higher than the pre-defined FIFO level, an interrupt signal will notify the host.

With the Magic Scan function and 4 k FIFO buffer, the I-8014W/I-8014CW can easily implement high-accuracy, high-speed and time-critical data acquisition applications.

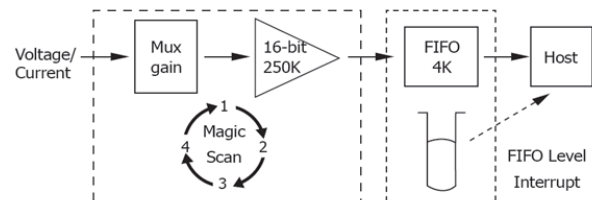

### System Specifications

Model	I-8014W	I-8014CW
<b>LED Display</b>		
System LED Indicator	Yes	
<b>Isolation</b>		
Intra-module Isolation, Field-to-Logic	2500 VDC	
<b>EMS Protection</b>		
ESD (IEC 61000-4-2)	$\pm 4$ kV Contact for each Terminal	
<b>Power</b>		
Consumption	2.5 W Max.	
<b>Mechanical</b>		
Dimensions (W x L x H)	30 mm x 102 mm x 115 mm	
<b>Environment</b>		
Operating Temperature	-25 ~ +75 °C	
Storage Temperature	-30 ~ +80 °C	
Humidity	10 ~ 90 % RH, Non-condensing	

### I/O Specifications

Model	I-8014W	I-8014CW	
<b>Analog Input</b>			
Channel	Single-ended	16	-
	Differential	8	
Input Range	Voltage	$\pm 1.25$ V, $\pm 2.5$ V, $\pm 5$ V, $\pm 10$ V	-
	Current	-20 ~ +20 mA (I-8014W requires Optional External 125 $\Omega$ Resistor)	
Resolution	16-bit		
Sample Rate	Single Channel Pacer Mode: 250 kS/s Single Channel Polling Mode: 45 kS/s 8 Channels Polling Mode: 25 kS/s		
FIFO Size	4 k words		
Accuracy	0.05 % of FSR		
Trigger Mode	Polling, Pacer (Magic Scan)		
Overvoltage protection	-45 ~ +60 VDC		
Input Impedance	20 K, 200 K, 20 M (Jumper Selectable)		125 $\Omega$

## Internal I/O Structure

### I-8014W

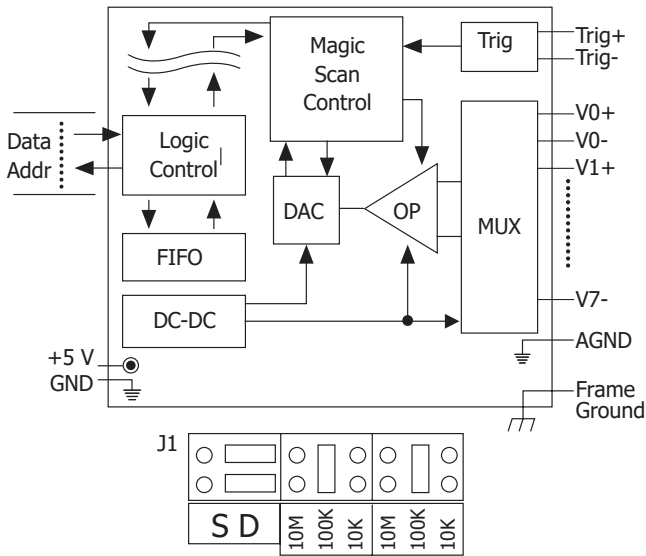

## Pin Assignments

### I-8014W

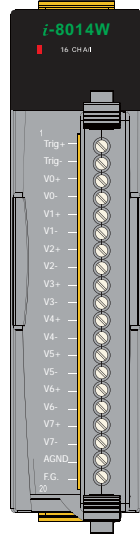

Terminal No.	Pin Assignment	
	Differential	Single-ended
01	Trig+	Trig+
02	Trig-	Trig-
03	V0+	V0
04	V0-	V8
05	V1+	V1
06	V1-	V9
07	V2+	V2
08	V2-	V10
09	V3+	V3
10	V3-	V11
11	V4+	V4
12	V4-	V12
13	V5+	V5
14	V5-	V13
15	V6+	V6
16	V6-	V14
17	V7+	V7
18	V7-	V15
19	AGND	AGND
20	F.G.	F.G.

### I-8014CW

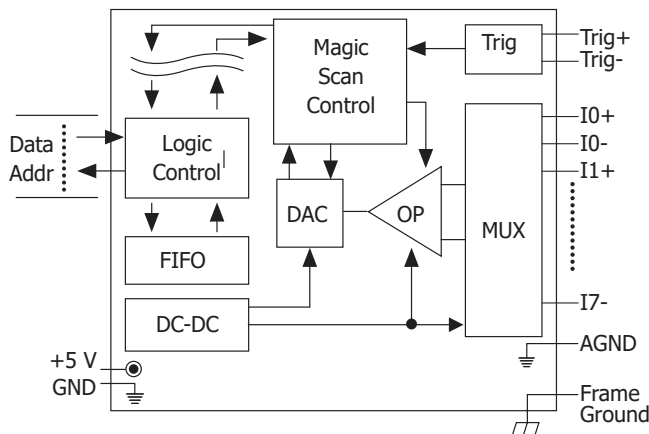

### I-8014CW

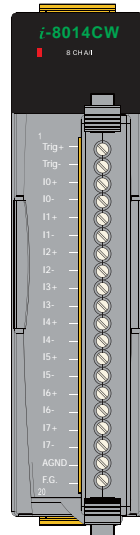

Terminal No.	Pin Assignment
01	Trig+
02	Trig-
03	I0+
04	I0-
05	I1+
06	I1-
07	I2+
08	I2-
09	I3+
10	I3-
11	I4+
12	I4-
13	I5+
14	I5-
15	I6+
16	I6-
17	I7+
18	I7-
19	AGND
20	F.G.

## Wire Connections

I-8014W		
Input Type	Differential	Singled-ended
Voltage	mV/V $\left[ \begin{array}{c} + \\ \ominus \\ \ominus \\ + \end{array} \right]$ Vin+ Vin-	mV/V $\left[ \begin{array}{c} + \\ \ominus \\ \ominus \\ + \end{array} \right]$ Vin AGND
Current	$\left[ \begin{array}{c} \uparrow \\ \ominus \\ \ominus \\ + \end{array} \right]$ Vin+ Vin- 125 $\Omega$	$\left[ \begin{array}{c} \uparrow \\ \ominus \\ \ominus \\ + \end{array} \right]$ Vin AGND 125 $\Omega$

I-8014CW	
Input Type	Differential
Current	$\left[ \begin{array}{c} \uparrow \\ \ominus \\ \ominus \\ + \end{array} \right]$ I+ I-

## Dimensions (Units: mm)

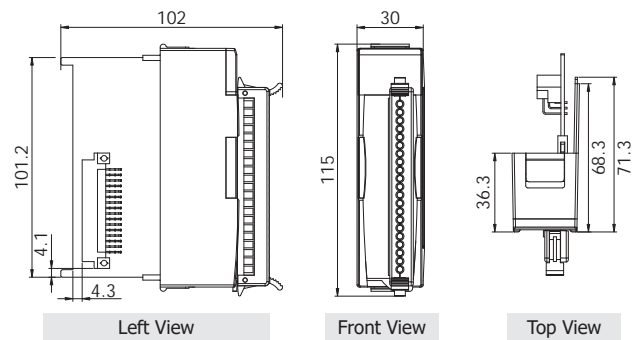

## Ordering Information

<b>I-8014W-G CR</b>	16-bit, 250 K sampling rate, 16/8-channel Analog Input Module (RoHS)
<b>I-8014CW-G CR</b>	R 16-bit, 250 K sampling rate, 8-channel Analog Input Module (RoHS)