



## USB-2019/S

USB I/O Module with 8-ch Universal AI  
with High Voltage Protection

### Features

- 8 Differential Universal Analog Input Channels
- 4kV ESD protection
- Wide Operating Temperature Range
- 240 Vrms Overvoltage Protection
- 3000 VDC Intra-Module isolation
- USB 2.0 Full-Speed (12 Mbps)
- USB Bus Powered
- Lockable USB cable
- Driver Free



### Introduction

The USB-2019 provided by ICP DAS is a new solution for data acquisition. It provides easy USB plug-and-play operation and equips accurate measurement for all kinds of automation applications. Compared with the traditional PC-based card like PCI, PC/104 and ISA cards, users can achieve data acquisition easier and quicker via USB-2019. The USB-2019 is an 8-ch universal analog input module and provides the following features. First, it supports the over-voltage protection of up to 240 Vrms. Second, it has voltage and current input types. Third, it widely supports thermocouple devices with J, K, T, E, R, S, B, N, C, L, M and LDIN43710 types. Fourth, it provides extremely accurate thermocouple measurement and automatically cold-junction compensation for each channel. Fifth, it features open wire detection for thermocouple and 4 ~ 20 mA inputs for each channel. Besides, through ICP DAS USB I/O utility, users can configure and test USB-2019 directly and easily without any coding. The friendly API library is also provided for users to develop own USB application.

### Applications

- Building automation
- Machine automation
- Environment control and monitoring
- Factory automation
- Data acquisition and control
- Laboratory equipment & research

### System Specifications

USB	
Specification	USB 2.0 Full-Speed (12Mbps)
Software	
OS Support	Windows XP (32/64 bit), Windows 7 (32/64 bit)
CPU Module	
Watchdog Timer	1 Hardware watchdog (1.6 second) 1 Software watchdog (Programmable)
Isolation	
Intra-module Isolation	3000 VDC
EMS Protection	
ESD (IEC 61000-4-2)	4 kV contact for each terminal 8 kV air for random point
LED Indicators	
Status	3 x Power and Communication
Power	
Consumption	1.7 W Max.
Mechanical	
Dimensions (mm)	USB-2019/S: 33 x 107 x 118 (W x L x H) CN-1824: 30 x 84 x 43 (W x L x H)
Environmental	
Operating Temperature	-25 ~ +75 °C
Storage Temperature	-40 ~ +85 °C
Humidity	10 ~ 95% RH, Non-condensing

### I/O Specifications

Analog Input		
Channels	8 Differential	
Type	Voltage, Current, Thermocouple	
Range	Voltage	±15 mV, ±50 mV, ±100 mV, ±150 mV, ±500 mV, ±1 V, ±2.5 V, ±5 V, ±10 V
	Current	±20 mA, 0 ~ 20 mA, 4 ~ 20 mA
	Thermocouple	J, K, T, E, R, S, B, N, C, L, M and LDIN43710
Resolution	16-bit	
Accuracy	±0.1% FSR	
Sampling Rate	10 Hz (Total)	
Input Impedance	Voltage Input	> 400 kΩ
	Current Input	125 Ω (An external resistor is required)
Common Mode Rejection	86 dB Min.	
Common Voltage Protection	100 dB	
Overvoltage Protection	240 Vrms	
Individual Channel Configuration	Yes	
Open Wire Detection	Yes (Software programmable)	
Zero Drift	±20 μV/°C	
Span Drift	±25 ppm/°C	

## Software

### USB IO Utility

USB IO Utility provides a simple way to easily test and instant acquire data for all ICP DAS USB IO series modules without programming.

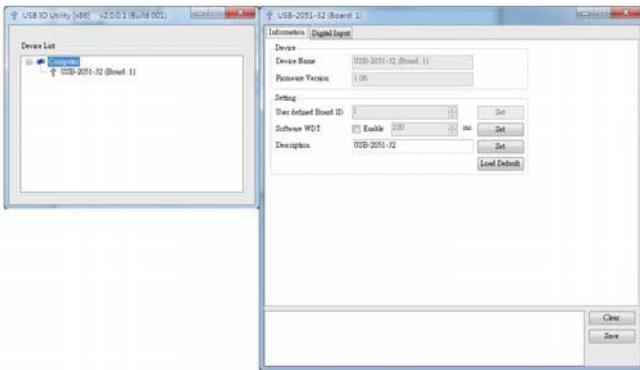

### .NET / VC / BCB / VB

ICP DAS provides a SDK for USB I/O modules to help user to develop own project easily and quickly. The SDK can be supported in various environments.

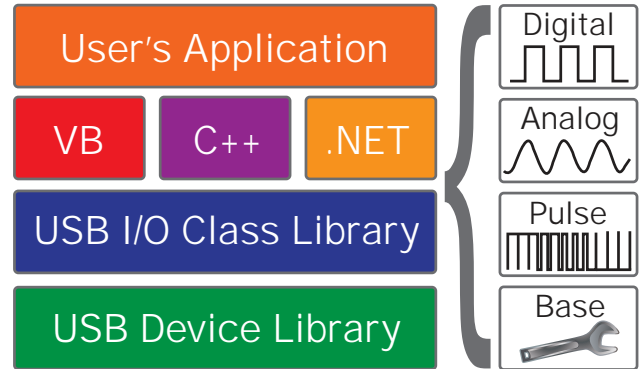

## Pin Assignments

### USB-2019

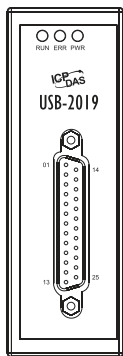

Pin Assignment	Terminal No.	Pin Assignment
+5V	1	14 AGND
CJC	2	15 CH 0+
CH 0-	3	16 CH 1+
CH 1-	4	17 CH 2+
CH 2-	5	18 CH 3+
CH 3-	6	19 CH 4+
CH 4-	7	20 CH 5+
CH 5-	8	21 CH 6+
CH 6-	9	22 CH 7+
CH 7-	10	23 N.C.
N.C.	11	24 N.C.
N.C.	12	25 N.C.
N.C.	13	Shield F.G.

25-pin Female D-sub Connector

### CN-1824

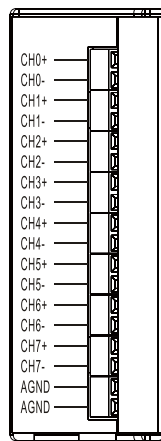

## Dimensions (Units: mm)

### USB-2019/S

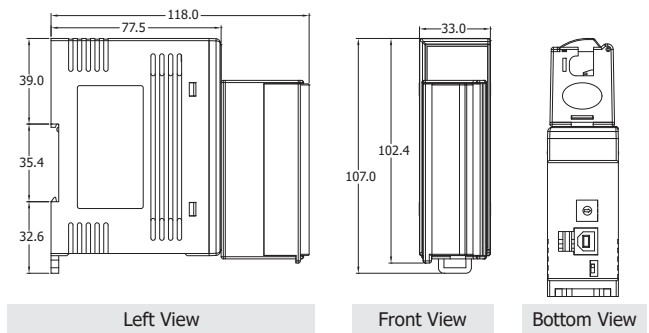

### CN-1824

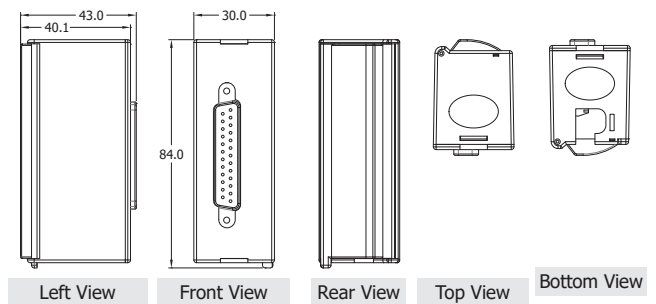

## Wire Connections

Voltage Input	Current Input	Thermocouple Input
	<p>Note: When connecting to current source, an external 125 Ω resistor is required.</p>	

## Ordering Information

<b>USB-2019/S CR</b>	USB I/O Module with 8-ch Universal AI with High Voltage Protection (RoHS) Includes CN-1824 Daughter Board and CA-USB15 Cable
----------------------	---