



## I-87037W-G

16-channel source type Isolated Digital Output Module

### Introduction

The I-87037W provides 16 channels for digital output, each of which features Photocouple isolation. The I-87037W supports source type output with short circuit protection and each channel can drive 700 mA load. There are options for configuring power-on and safe digital output values. 4 kV ESD protection and 3750 Vdc intra-module isolation are also provided to enrich the noise protection ability for industrial environment.

### Features

- Source Type Digital Outputs
- Photocouple Isolation
- 4 kV ESD Protection
- Dual Watchdog
- Power-on Value Setting
- Safe Value Setting
- Short Circuit Protection
- 3750 Vdc Intra-module Isolation
- RoHS Compliant
- Wide Operating Temperature Range: -25 to +75°C



### Applications

- Industrial Automation
- Industrial Machinery
- Building Automation
- Food and Beverage Systems
- Semiconductor Fabrication
- Control Systems

### System Specifications

Communication	
Interface	RS-485
Format	N, 8, 1
Baud Rate	1200 to 115200 bps
Protocol	DCON
Dual Watchdog	Yes, Module (1.6 Seconds), Communication (Programmable)
LED Indicators/Display	
System LED Indicators	Yes, 1 as Power/Communication Indicator
I/O LED Indicators	16 as High/Low Alarm Signals
Isolation	
Intra-module Isolation, Field-to-Logic	2500 Vdc
EMS Protection	
ESD (IEC 61000-4-2)	±4 kV Contact for each Terminal
	±8 kV Air for Random Point
Power	
Power Consumption	0.41 W
Mechanical	
Dimensions (L × W × H)	115 mm × 30 mm × 102 mm
Environment	
Operating Temperature	-25 to +75°C
Storage Temperature	-40 to +85°C
Humidity	10 to 95% RH, Non-condensing

### I/O Specifications

Digital Output	
Channels	16
Type	Open Emitter
Sink/Source (NPN/PNP)	Source
Load Voltage	+10 Vdc ~ +40 Vdc
Max. Load Current	700 mA/channel
Overvoltage Protection	47 VDC
Overload Protection	Yes
Short Circuit Protection	Yes
Power-on Value	Yes
Safe Value	Yes

## Internal I/O Structure

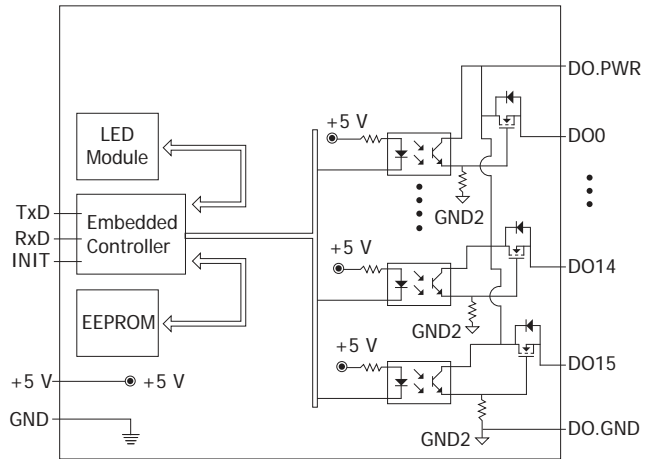

## Dimensions (Units: mm)

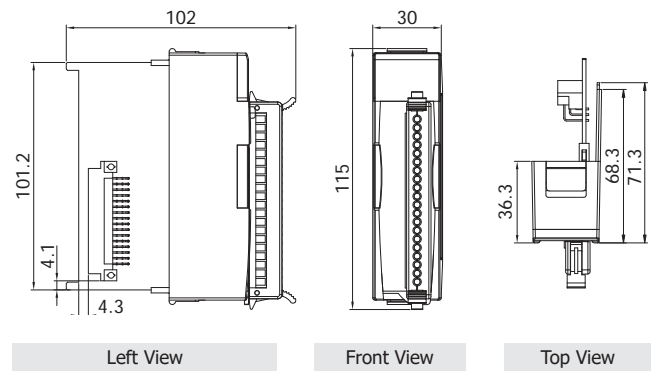

## Wire Connections

Output Type	ON State LED ON Readback as 1	OFF State LED OFF Readback as 0
	Relay ON	Relay OFF
Drive Relay		
Resistance Load		

## Pin Assignments

Terminal No.	Pin Assignment
01	DO0
02	DO1
03	DO2
04	DO3
05	DO4
06	DO5
07	DO6
08	DO7
09	DO8
10	DO9
11	DO10
12	DO11
13	DO12
14	DO13
15	DO14
16	DO15
17	DO.GND
18	DO.GND
19	DO.PWR
20	DO.PWR

## Ordering Information

<b>I-87037W-G CR</b>	16-channel Source Type Isolated Digital Output Module (Gray Cover) (RoHS)
----------------------	---

## Accessories

SG-770 CR	7-channel Differential or 14-channel Single-ended Surge Protector (RoHS)
-----------	--